



SWIVEL FILL / VAPOR ADAPTER

MODELS B-70B, B-75A & B-75B

MADE IN BRASS AND HARD NICKEL PLATED ALUMINUM

B7X Swivel Adapters



Patented

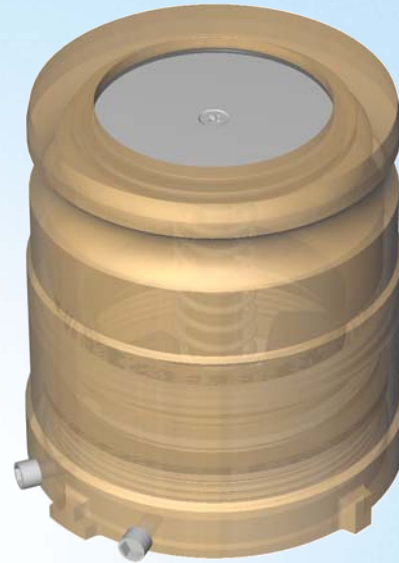

The B-70 features a top section that swivels & rotates 360° with loading nozzle movement and/or hydraulic shock, while the bottom section remains securely sealed to the 4-inch tank riser.

Quality, durable stainless steel ball bearing design, allowing excellent electrical conductivity and eliminating static discharges.

CARB approved, swivel adapter reduces fugitive emissions. No direct product or vapor release.

Integrated venturi design for improved product flow through adapter and drop tube.

Compatible with all current fuels and fuel additives. Utilizes teflon/viton seal that will not dry out.

The B-75 features a top section that swivels & rotates 360° with loading nozzle movement and/or hydraulic shock, while the bottom section remains securely sealed to the 4-inch tank riser.

Poppet assembly is integrated with the swivel sleeve to prevent undue stress to poppet while rotating the swivel sleeve.

CARB approved, swivel vapor adapter reduces fugitive emissions. No direct product or vapor release.

Integrated venturi design for improved product flow through adapter and drop tube.

Compatible with all current fuels and fuel additives. Utilizes teflon/viton seal that will not dry out.

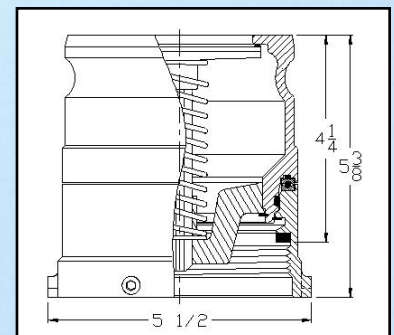
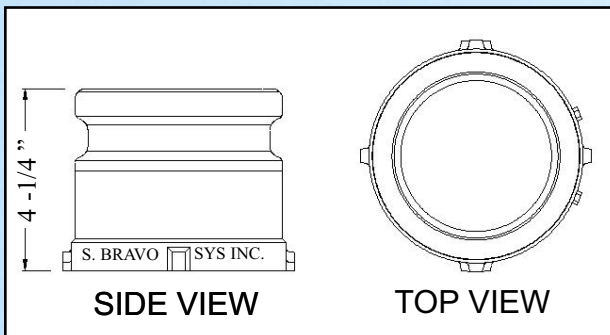

S. Bravo Systems, Inc. - The Leader in Secondary Containment

2929 Vail Ave. | Commerce, CA | 323-888-4133 | FAX: 323-888-4123 | www.sbravo.com



10A